

Nokia Customer Care
RH-51/52, RH-67/68 Series Cellular Phones

7 - System Module

This page has been deliberately left blank

Table of Contents

	Page No
Glossary of terms.....	5
Introduction	6
System module block diagram	6
Functional description.....	7
BB description	7
Memory configuration	7
Energy management.....	8
Modes of operation	8
Voltage limits.....	9
Clocking scheme	9
UPP_WD2 voltage/clock frequency adjusting.....	10
Power distribution, control and reset	10
Power-up sequence (reset mode).....	11
Powering off.....	11
Controlled powering off.....	11
Uncontrolled powering off.....	11
Watchdogs.....	11
Charging	12
Chargers.....	12
Battery	12
Back-up battery and real time clock	12
Baseband measurement A/D converter	12
ZOCUS.....	13
RH-51/52, RH-67/68 baseband features and HW interfaces	14
RH-51/52, RH-67/68 BB user interface	14
UI-module interface.....	14
Bluetooth	14
USB	14
SIM interface	14
MMC interface	14
RF PopPort™	14
RH-51/52, RH-67/68 audio concept	15
Earpiece	15
Microphone	16
IHF amplifier and speaker.....	16
External audio interface	16
Camera interface	17
Flashing	17
Testing interfaces	18
Extreme voltages	19
Temperature conditions	19
Humidity and water resistance	19
RF description.....	20

List of Figures

	Page No
Fig 1 Module block diagram	6
Fig 2 RH-51/52, RH-67/68 clocking.....	10
Fig 3 RH-51/52, RH-67/68 audio blocks.....	15
Fig 4 External audio connector.....	17

Glossary of terms

ASIC	Application Specific Integrated Circuit
BB	Baseband
BT	Bluetooth
BSI	Battery Size Indicator
CBus	MCU controlled serial bus connected to UPP_WD2,UEME and Zocus
CCP	Compact Camera Port
CPU	Central Processing Unit
DBus	DSP controlled serial bus connected between UPP_WD2 and Helgo
DSP	Digital Signal Processor
EGSM	Extended – GSM
GPRS	General Packet Radio Service
GSM	Group Special Mobile/Global System for Mobile communication
HF	Hands free
HFCM	Handsfree Common
HS	Handset
I/O	Input/Output
IHF	Integrated hands free
JPEG	Joint Photographic Experts Group
LCD	Liquid Crystal Display
MCU	Micro Controller Unit
MIC, mic	Microphone
PDA	Pocket Data Application
PWB	Printed Wiring Board
RF	Radio Frequency
RFBUS	Serial control Bus For RF
RF PopPort™	Reduced function PopPort™ interface
RS-MMC	Reduced size Multi Media Card
SDRAM	Synchronous Dynamic Random Access Memory
SIM	Subscriber Identity Module
UI	User Interface
UEME	Universal Energy Management chip (Enhanced version)
VCXO	Voltage Controlled Crystal Oscillator

Introduction

The system module RH-51/52, RH-67/68 consists of radio frequency (RF) and baseband (BB), including user interface (UI) with keyboard.

System module block diagram

The 1BZ system module is the engine board of the RH-51/52, RH-67/68 phone. It includes the baseband and RF functions of the phone and Bluetooth and camera modules as shown in the figure below. External interfaces are drawn as arrows crossing the 1BZ border.

Figure 1: Module block diagram

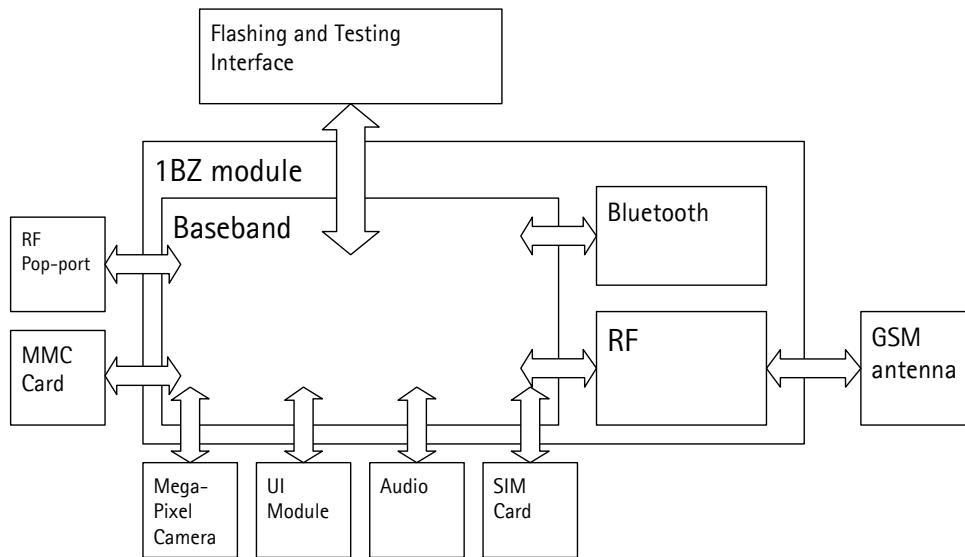

The accessory interface is provided by Bluetooth and Reduced Function PopPort™. RH-51/52, RH-67/68 has a PopPort™ connector but no ACI interface internally, so it's called the RF PopPort™.

RH-51/52, RH-67/68 uses the same connector as another PopPort™ phone but it can't communicate with ACI accessory. Monoural headsets, charger and camera flash are interfaced via the RF PopPort™ and BT headset, and some BT accessories are interfaced via Bluetooth.

Functional description

The heart of the BB is UPP_WD2, which includes the MCU, DSP and Digital Control Logic. Power is supplied by the UEME ASIC and a number of discrete regulators. Memory comprises of 2 x 128Mbit Stacked and 64Mbit flash memory devices and 128 Mbit (16 Mbytes) SDRAM.

There are two audio transducers (earpiece 8 mm and IHF speaker 16 mm) and external galvanic headset (PopPort™) interface. The IHF speaker is also used to handle the ring tone. The IHF speaker is driven by a discrete audio amplifier. In RH-51/52, RH-67/68 there is only one microphone for both HS and IHF modes.

For data connectivity there is USB v2.0 full-speed, Bluetooth and RS-MMC card.

The display is an TFT type colour display with 65536 colours and 176x208 pixels with backlighting. The UI module features a round keymat and a navigation key.

For imaging purposes, BB supports a mega-pixel camera via the CCP interface, which is integrated in UPP_WD2.

BB description

The BB core is based on UPP_WD2 CPU, which is a PDA version of the DCT4 UPP ASIC. UPP_WD2 takes care of all the signal processing and operation controlling tasks of the phone as well as all PDA tasks.

For power management, there is one main ASIC for controlling charging and supplying power UEME plus some discrete power supplies. The main reset for the system is generated by the UEME.

The interface to the RF and audio sections is also handled by the UEME. This ASIC provides A/D and D/A conversion of the in-phase and quadrature receive and transmit signal paths and also A/D and D/A conversions of received and transmitted audio signals. Data transmission between UEME and RF and the UPP_WD2 is implemented using different serial connections (CBUS, DBUS and RFBUS). Digital speech processing is handled by UPP_WD2 ASIC.

A real time clock function is integrated into UEME, which utilizes the same 32kHz-clock source as the sleep clock. A rechargeable battery provides backup power to run the RTC when the main battery is removed. Backup time is approximately 5 Hours.

Memory configuration

RH-51/52, RH-67/68 uses two kinds of memories, Flash and SDRAM. These memories have their own dedicated bus interfaces to UPP_WD2.

Synchronous DRAM is used as the working memory. Interface is 16 bit wide data and 14 bit address. Memory clocking speed is 123.5 MHz. The SDRAM size is 128Mbits.

SDRAM I/O is 1.8 V and core 1.8 V supplied by UEME regulator VIO. All memory contents

are lost if the supply voltage is switched off.

Multiplexed flash memory interface is used to store the MCU program code and user data. The memory interface is a burst type FLASH with multiplexed address/data bus, running at 123.5/3MHz.

Configuration of flash memory is a 2x128Mbit stacked flash memory and a 64Mbit flash memory.

Both flash I/O and core voltage are 1.8 V supplied by UEME's VIO.

Energy management

The master of EM control is UEME and with SW it has the main control of the system voltages and operating modes.

Modes of operation

RH-51/52, RH-67/68 employs several hardware and software controlled operation modes. Main modes are described below.

- NO_SUPPLY mode means that the main battery is not present or its voltage is too low (below UEME master reset threshold) and back-up battery voltage is too low.
- In BACK_UP mode the main battery is not present or its voltage is too low but the back-up battery has sufficient charge in it.
- In PWR_OFF mode the main battery is present and its voltage is over the UEME master reset threshold. All regulators are disabled.
- RESET mode is a synonym for start-up sequence and contains in fact several modes. In this mode, regulators and oscillators are enabled and after they have stabilized system reset is released and PWR_ON mode entered.
- In PWR_ON mode SW is running and controlling the system.
- SLEEP mode is entered from PWR_ON mode when the system's activity is low (SLEEPX controlled by SW).
- FLASHING mode is for production SW download.

Voltage limits

The voltage limits of the system are listed in the following table. These are also controlling system states.

Parameter	Description	Value
V_{MSTR+}	Master reset threshold (rising)	2.1 V (typ.)
V_{MSTR-}	Master reset threshold (falling)	1.9 V (typ.)
V_{COFF+}	Hardware cutoff (rising)	3.1 V (typ.)
V_{COFF-}	Hardware cutoff (falling)	2.8 V (typ.)
$V_{BU_{COFF+}}$	Back-up battery cutoff (rising)	2.1 V (typ.)
$V_{BU_{COFF-}}$	Back-up battery cutoff (falling)	2.0 V (typ.)
SW_{COFF}	SW cutoff limit (> regulator drop-out limit) MIN!	3.4 V SW changeable

The master reset threshold controls the internal reset of UEME. If battery voltage is above V_{MSTR} , UEME's charging control logic is alive. Also, RTC is active and supplied from the main battery. Above V_{MSTR} UEME allows the system to be powered on although this may not succeed due to voltage drops during start-up. SW can also consider battery voltage too low for operation and power down the system.

Clocking scheme

A 26 MHz VCXO is used as system clock generator in GSM. During the system start-up, UEME RC-oscillators generate timing for state machines. All clock signals of the engine are illustrated in following figure.

Bluetooth uses a 26 MHz clock.

In SLEEP mode, the VCXO is off. UEME generates low frequency clock signal (32.768 kHz) that is fed to UPP_WD2, Bluetooth and ZOCUS.

Figure 2: RH-51/52, RH-67/68 clocking.

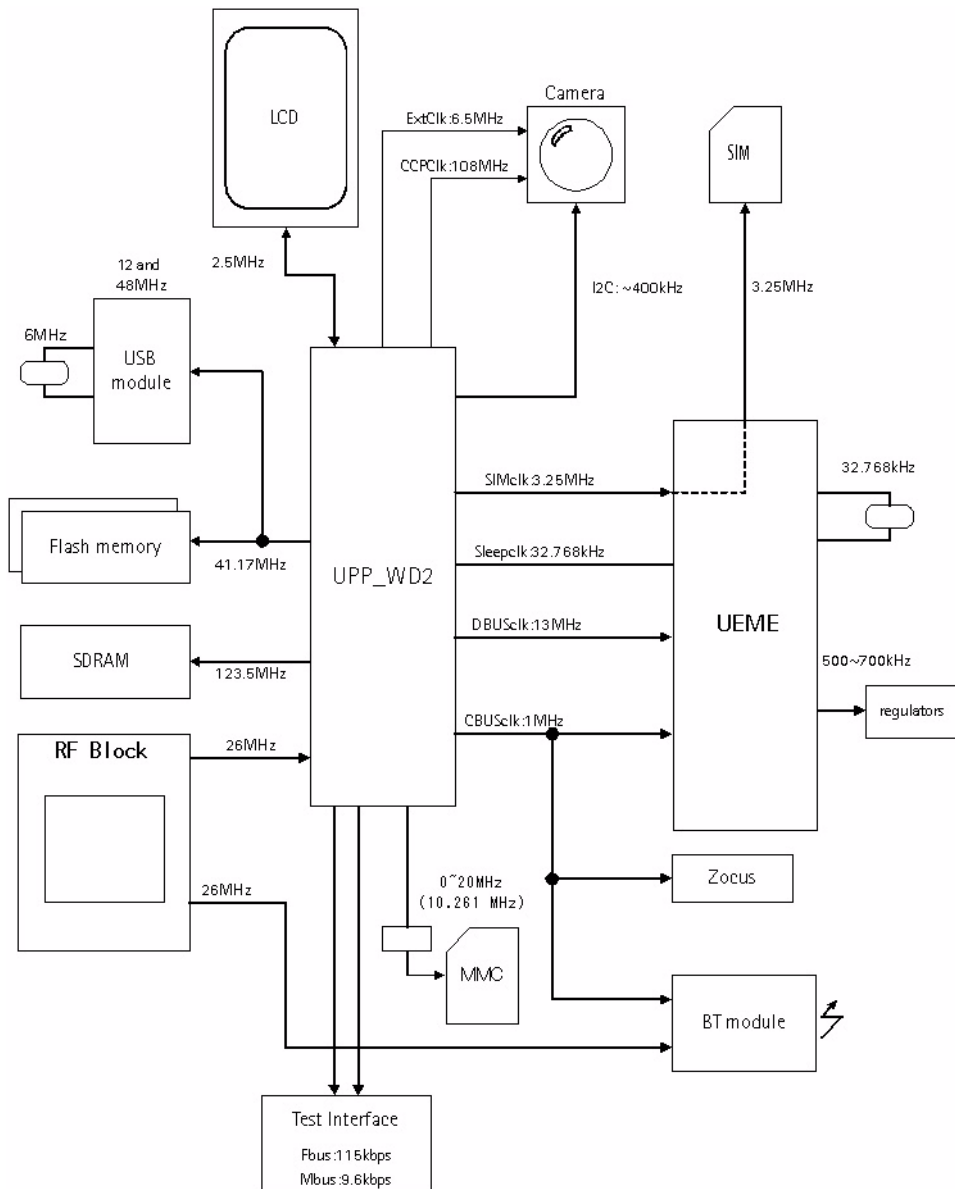

UPP_WD2 voltage/clock frequency adjusting

No external clock is available for UPP_WD2 before VCXO starts. As reset is released, the VCXO is running and MCU uses the 26 MHz clock while DSP is in reset. There are three identical DPLL's, for MCU, for DSP and for accessory interfaces, which can be controlled independently. The clock for MCU can be up to 130 MHz and 156 MHz is maximum clock frequency for the DSP. These clock signals are used either directly (SDRAM IF) or divided down for the interfaces (e.g. flash IF).

Power distribution, control and reset

All power (except backup battery power) is drawn from the BL-5C Li-Ion battery located in the B cover. Current flows through ZOCUS current sense resistor which is used for current measurement by ZOCUS and thus for remaining operating time estimation.

1BZ board contains one power ASIC, UEME and discrete regulators needed for generating

the different operating voltages. The discrete regulators consist of an SMPS to power UPPWD2 voltage core. In addition, there is a SMPS in 1BZ generating the operating voltage for display module backlighting. In 1BZ, the keyboard backlight is powered with a charge pump regulator.

Power-up sequence (reset mode)

RESET mode can be entered in four ways: by inserting the battery or charger, by RTC alarm or by pressing the power key. The VCXO is powered by UEME. After a 220 ms delay, regulators are configured and UEME enters PWR_ON mode and system reset PURX is released.

During the system start-up, in RESET state, the regulators are enabled, and each regulator charges the capacitor(s) at the output with the maximum current (short circuit current) it can deliver. This results in battery voltage dropping during start-up. When a battery with a voltage level just above the hardware cutoff limit is inserted, the system may not start due to excessive voltage dipping. Dropping below 2.8 V for longer than 5 us forces the system to PWR_OFF state.

Powering off

Controlled powering off is done when the user requests it by pressing the power-key or when the battery voltage falls too low. Uncontrolled powering off happens when the battery is suddenly removed or if over-temperature condition is detected in regulator block while in RESET mode. Then all UEME's regulators are disabled immediately and discrete regulators are disabled as Vbat supply disappears.

Controlled powering off

For RH-51/52, RH-67/68, powering off is initiated by pressing the power key and power off sequence is activated in UEME and SW. Basically, the power key causes UEME interrupt to UPP_WD2 and SW sets watchdog time value to zero and as this happens, PURX is forced low and all regulators are disabled.

If the battery voltage falls below the very last SW-cutoff level, SW will power off the system by letting the UEME's watchdog elapse.

If thermal shutdown limit in the UEME regulator block is exceeded, the system is powered off. System reset PURX is forced low.

Uncontrolled powering off

This happens when the battery is suddenly removed. UEME's state machine notices battery removal after the battery voltage has been below V_{COFF-} for 5 us and enters PWR_OFF mode. PURX is set low and all UEME's regulators are disabled.

Watchdogs

There are three watchdogs in UEME. The first one is for controlling system power-on and power-down sequences. The initial time for this watchdog after reset is 32 s and the watchdog can not be disabled. The time can be set using a register. This watchdog is used for powering the system off in a controlled manner. The other one is for security block

and is used during IMEI code setting. The third one is a power key watchdog. It is used to power off the system in case SW is stuck and the user presses the power key. This WD is SW configurable.

There is also a "soft watchdog" in UPP_WD2. It is used to reset the chip in case software gets stuck for any reason.

Charging

Charging control and charge switch is in UEME. There are two different charging modes; charging an empty battery (start-up charge mode), and SW controlled charging.

UEME digital part takes care of charger detection (generates interrupt to UPP_WD2), pulse width modulated charging control (for internal charge switch) and over voltage and current detection. SW using registers controls all these.

Chargers

RH-51/52, RH-67/68 BB supports a standard charger (two wires); ACP-12 and cigarette charger LCH-12 officially.

Battery

RH-51/52, RH-67/68 battery is a detachable, semi-fixed lithium-Ion BL-5C battery. The nominal voltage is thus 3.7 V (max charging voltage 4.2 V).

The interface consists of three pins: VBAT, GND and BSI. A pull-down resistor inside the batteries (BSI signal) recognizes the battery types. The voltage level at BSI line is measured using UEME's AD-converter.

Back-up battery and real time clock

The real time clock (RTC), crystal oscillator and back-up battery circuitry reside in UEME. A register in UEME controls back-up battery charging and charging is possible only in POWER_ON State.

Baseband measurement A/D converter

UEME contains an 11 channels A/D converter, which is used for different baseband measurement purposes. The resolution of the A/D converter is 10 bits. The converter uses the CBUS interface clock signal for the conversion. An interrupt will be given to the MCU at the end of the measurements. The converter is used for following purposes.

- Battery Voltage Measurement A/D Channel (Internal)
- Charger Voltage Measurement A/D Channel (Internal)
- Charger Current Measurement A/D Channel (Internal)
- Battery Temperature Measurement A/D Channel (External)
- Battery Size Measurement A/D Channel (External)
- LED Temperature measurement A/D Channel (External)

There is also an auxiliary AD converter in UEME, which is used to monitor RF functions.

ZOCUS

The ZOCUS device is a current sensor used for the battery bar display and for determining whether the phone is in a high current consuming mode. The ZOCUS device measures the voltage drop across a sense resistor in the battery voltage line. This sense resistor is formed from a PWB track and is on an internal layer of the PWB. The sense resistor must be located close to the battery terminals so that all of the phones current flow through it. The nominal value of the sense resistor is 3.0m-ohm. ZOCUS reports the current measurement to UPP_WD2 via the Cbus interface.

RH-51/52, RH-67/68 baseband features and HW interfaces

RH-51/52, RH-67/68 BB user interface

UI-module interface

The UI-module consists of the LCD and keymat. The colour display resolution is 176 x 208 and backlighting is via 4 white LED's. The display is connected to the 1BZ module via an 24 pin plug and socket. The keymat is connected to 1BZ by 20-pin contact type connector. The interface also includes power rails for keypad backlight. The keymat interface uses GPIO pins of UPP_WD2.

Bluetooth

Bluetooth provides a fully digital link for communication between a master unit and one or more slave units. The system provides a radio link that offers a high degree of flexibility to support various applications and product scenarios. Data and control interface for a low power RF module is provided. Data rate is regulated between the master and the slave.

USB

USB provides a wired connectivity between host PC and peripheral devices. RH-51/52, RH-67/68 complies with USB 2.0, supporting data transfer at full-speed (max. 12Mbps). The USB functionality of RH-51/52, RH-67/68 is implemented by a newly developed USB interface device, Kaede (NMP code is 4342163), which is connected to UPP_WD2 via flash memory interfaces. A 6MHz ceramic resonator, Ceralock (NMP code is 451B099), is used for USB clock generation.

SIM interface

The SIM interface is located in two chips (UPP_WD2 and UEME). In UEME there is support only for one SIM card. The interfaces support both 1.8 V and 3 V SIM cards. Adjustable SIM regulator (1.8V/3.0V) is located in UEME and can be controlled by SW.

The data communication between the card and the phone is asynchronous half duplex. The clock supplied to the card is 3.25 MHz. The data baudrate is SIM card clock frequency divided by 372 (by default), 64, 32 or 16.

MMC interface

The MMC interface consists of a block in UPP_WD2 plus a level shifting device known as "Lester" and an EMC protection ASIP. The MMC interface comprises 3 lines clock, data and command and runs at 8.66 MHz. The Lester device also incorporates a 2.85V regulator to power the MMC card.

RF PopPort™

RH-51/52, RH-67/68 use same PopPort™ connector same as other PopPort™ phones but it can't communicate with ACI accessory such as HDS-3 stereo headset due to the lack of ACI module in UPP_WD2.

Multiplexed data lines of USB and Fast-Fbus are also single usage for USB only cause USB chip doesn't have such functionality.

Hence there's no PopPort™ stereo headset without ACI chip in it, RH-51/52, RH-67/68 uses only the mono headset interface.

RH-51/52, RH-67/68 audio concept

RH-51/52, RH-67/68 audio includes an earpiece, a microphone, and a PopPort™ connector for headset and integrated handsfree (IHF). Audio is based on ASIC's UPP_WD2, UEME and a discrete amplifier for the handsfree speaker known as "boomer".

Figure 3: RH-51/52, RH-67/68 audio blocks

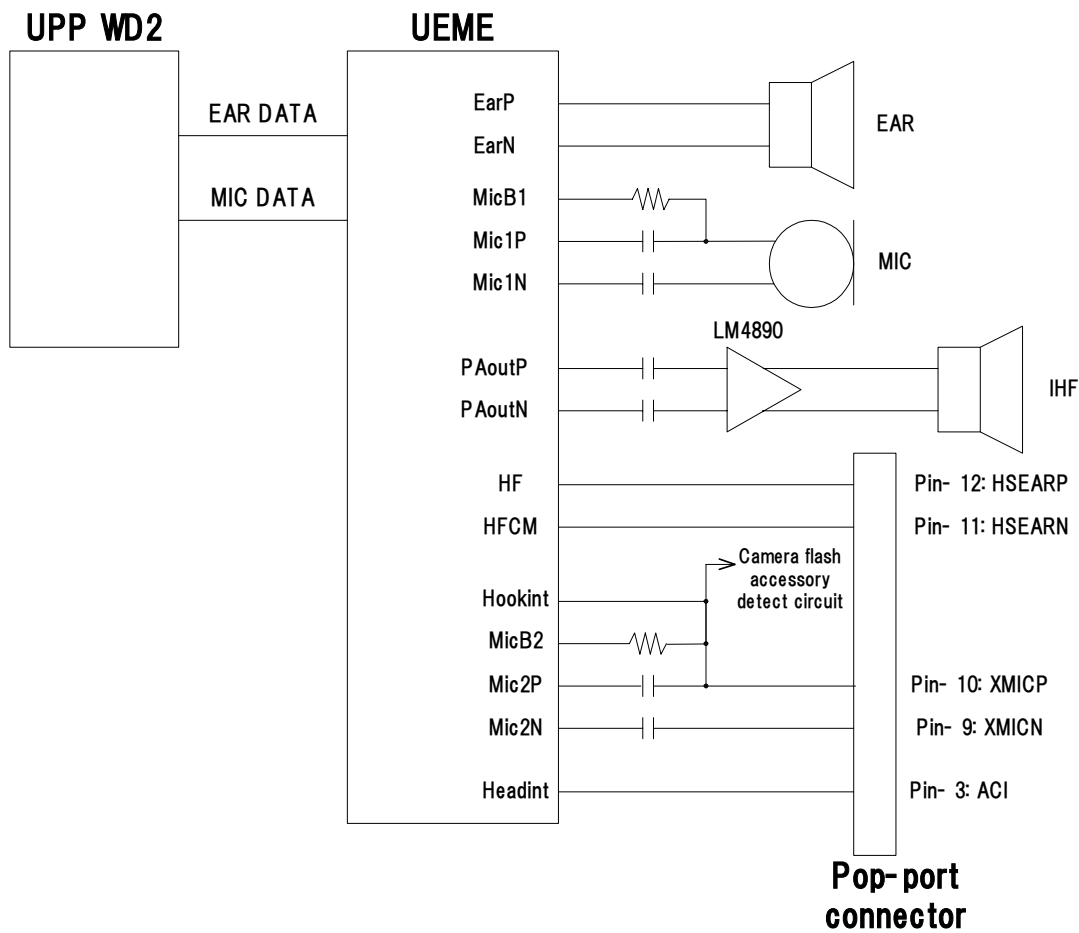

Between UPP_WD2 and UEME, the audio signals are transferred in digital format using signals MICDATA and EARDATA. Ringing tones and warning/info tones are to be produced to the IHF speaker.

Earpiece

The earpiece to be used in RH-51/52, RH-67/68 is an 8-mm Pico earpiece produced by Philips Speaker Systems. It has 32Ω continuous impedance and continuous power 8

mWatts. It's driven by differential signals from UEME (EARP & EARN). It makes contact with the PWB via spring contacts.

Microphone

The microphone module for RH-51/52, RH-67/68 is used PopPort™ microphone module. Its sensitivity is -42dB Nominal. Contacts are done by springs.

Two inputs are used from UEME, one for the normal internal microphone and the other for the headset. The third microphone input is not used, so it is connected to ground via capacitors. Microphone bias block in UEME generates bias voltages for handportable and handsfree/headset microphones. For both microphone bias outputs (MICB1 & MICB2), the minimum output voltage is 2.0 Volts and maximum output current is 600 μ A. Microphone bias block also includes a low pass filter for the reference voltage used as an input for the MICB1&2 amplifiers.

IHF amplifier and speaker

The speaker to be used in RH-51/52, RH-67/68 is a 16mm 8 Ω speaker. It can handle 0.3 Watts nominal power and short term peak power of 0.8 Watts. The component is housed in the antenna housing and connects to the PWB via spring contacts.

PAOUTP and PAOUTN lines of UEME are use to drive Boomer IHF amplifier.

Power amplifier is a differential opamp. The differential output drives the HandsFree speaker. HandsFree amplifier load impedance is 8 ohm.

The outputs go into a high impedance state when powered down. The amplifier can be enabled and shut down using a GENIO line from UPP_WD2.

SW controls IHF, headset and earpiece volume via UEME. Gain setting can be done in 2 dB steps, from -40 to +6 dB. The output sound pressure level of the internal HandsFree speaker is controlled by SW (CBus is used for controlling).

The schematic around the Boomer IHF amplifier is presented in RH-51/52, RH-67/68 schematics. The schematic shows all the filtering needed and also protection components against ESD and EMC. The EMC and ESD filtering component must be as near as possible to the earphone pads of the phone.

The supply voltage for the IHF amplifier is taken directly from the battery voltage.

External audio interface

In RH-51/52, RH-67/68 there is a PopPort™ connector which is fully differential 4-wire connection.

Figure 4: External audio connector

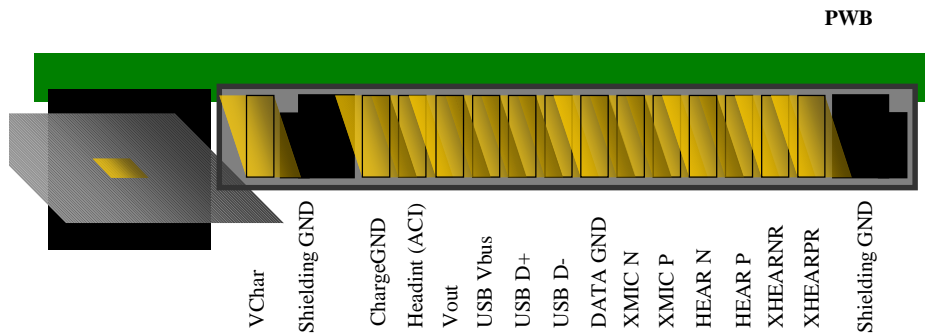

The handsfree (HF) driver in UEME is meant for the headset. In RH-51/52, RH-67/68, the output is driven in fully differential mode. In the fully differential mode, the HF pin is the negative output and the HFCM pin is the positive output. The gain of the handsfree driver in the differential mode is 6 dB. The earpiece (EARP, EARN) and headset (HF, HFCM) signals are multiplexed so that the outputs can not be used simultaneously. The HF and HFCM amplifiers include a transient suppression circuitry, which prevents unwanted spikes in HF and HFCM outputs when switching on and off the amplifiers.

The HeadInt line will be pulled up to 2.7V by the internal resistor when the accessory is connected. When not having the accessory inserted the voltage in the HeadInt line will be <0.8 V caused by internal pull down resistor in the HF line.

Camera interface

RH-51/52, RH-67/68 has a digital still camera with viewfinder function. The camera resolution is VGA (640 x 480 pixels) and 1M Pixel (1152 x 864 pixels). The camera module is connected by means of a soldered on connector to the PWB.

The camera interface is a serial CCP, which is an unidirectional interface; the control information to camera is transmitted through I2C bus. The I2C bus is implemented purely by the SW using general purpose I/Os.

The CCP interface consists of differential clock and data signals. The CCP enables the use of high data rates with low EMI; maximum transfer capacity is 108Mbit/s, which means that transferring YUV VGA(640 x 480) or 1Mp JPEG encoded images at 15fps is possible.

The camera needs two power sources, 2.5V for analog circuit voltage VDD and 1.5V for digital circuit voltage VDDI. VDD is provided from same discrete regulator as LCD and VDDI is fed from UEME's Vcore.

Flashing

SW download in service is implemented by custom tools and SW, kindly refer to Service Software Instructions and Service Tool section of the manual.

Testing interfaces

RH-51/52, RH-67/68 has a testing interface that is easy to access by service battery. The following signals are allocated on test pads.

Table 1: Testing interface electrical specifications

Pad No	Name	Dir	Parameter	Min	Typ	Max	Unit	Notes
1	STI_Rx	<-	Vil (From Ostrich)	0		0.3*VIO	V	
			Vih (From Ostrich)	0.7*VIO		VIO	V	
2	STI_CLK	->	Vo			0.22*VIO	V	
			Voh	0.8*VIO			V	
3	VPP		To Phone	0 / 2.8 / 9 +/-3%			V	Prommer Select
4	FBusTx	->	Vol	0	2.7	0.3*VFlash1	V	
			Voh	0.7*VFlash1	2.7	VFlash1	V	
5	MBUS	<->	Vol	0	0.2	0.3*VFlash1	V	
			Vil (From prommer)	0	0.2	0.3*VFlash1	V	
			Voh	0.7*VFlash1	2.7	0.7*VFlash1	V	
			Vih(From prommer)	0.7*VFlash1	2.7	VFlash1	V	
6	FBusRx	<-	Vil (From prommer)	0	2.7	0.3*VFlash1	V	
			Vih(From prommer)	1.89	2.7	VFlash1	V	
			Abs. Max. Voltage to Test Pad Referenced to GND	-0.3V		3.0	V	Absolute Max Voltage limits to MBUS/FBUS
7,9	GND				0		V	VBAT GROUND
8	STI_Tx	->	Vo			0.22*VIO	V	
			Voh	0.8*VIO			V	

Note 1: VFlash1 = 2.78 +/-3%, VIO = 1.8 +/- 4.5%

Table 2: Electrical specifications for power supply interface in production testing

Pin	Name	Min	Typ	Max	Unit	Notes
1	VBAT	0	3.6	5.1	V	
2	BSI	0	2.78	VFlash1	V	Internal pullup
3	GND	0			V	

Extreme voltages

Lithium-Ion battery BL-5C (1 cell):

- Nominal voltage is 3.7V
- Lower extreme voltage is 2.8V (cut off voltage)
- Higher extreme voltage is 4.2V (charging high limit voltage)

Temperature conditions

Specifications are met within the range of -10°C to $+55^{\circ}\text{C}$ ambient temperature.

Reduced operation between $[-30]$ and $[+60]$. Storage temperature range is of -40°C to $+85^{\circ}\text{C}$.

Humidity and water resistance

Relative humidity range is 5 to 95%. Condensed or dripping water may cause intermittent malfunctions. Protection against dripping water have to be implemented in (enclosure) mechanics. Continuous dampness will cause permanent damage to the module.

RF description

RH-51, -67 is the GSM900/1800/1900 version and RH-52, -68 is the GSM850/1800/1900 version. The difference in RF module is 2 SAW filters, a capacitor on the 1BZ system module, and antenna module.

The main ASIC of RF is Helgo 85G/86G, and power amplifier is RFMD RF9250, so called microPA. RH-51/52, RH-67/68 does not support EDGE, even though the RF module itself has the capacity for it.

The BC02 solution is used for Bluetooth. The ASIC and components are placed on the bottom side of 1BZ system module, underneath the shield can with UPP_WD2.

For more details, see General description in RF Troubleshooting section.